

**CLICK'N'RIDE**  
QUICK RELEASE MOTORCYCLE TURN SIGNALS

DIRT ADVENTURE TRACK

# Prima | Nova Series

Quick-Release LED Turn Signals

**“NEVER  
SMASH YOUR  
TURN SIGNALS  
AGAIN WHEN YOU  
RIDE OFF-ROAD,  
TRAILS OR LAP  
TRACKS!”**



Ride well



# Why?

Removable blinkers -  
the ultimate protection for turn signals.

Let's face it, we all play hard. And the toys we play on are bound to take some abuse but all too often we found ourselves spending too much time in the garage fixing blinkers instead of being out riding with our mates.

So we did something about it...

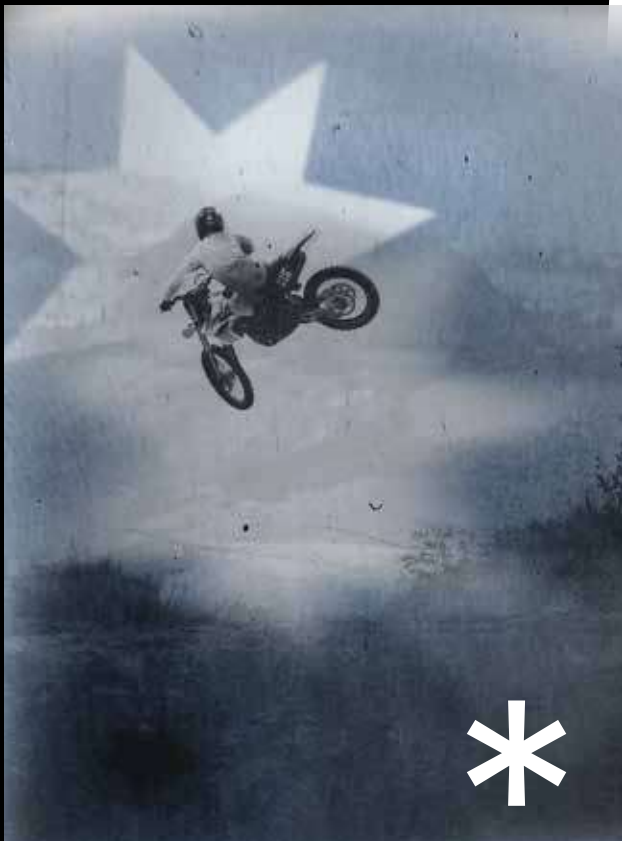

Bush-bash, verb Australian slang. 1. to clear scrubland. 2. to drive or ride through thick scrubland.

**From humble beginnings (and a great deal of frustration) an idea was born...**

CLICKnRIDE was born in the garage when we got sick of busting our turn signals when bush-bashing\* and invented removable turn signals that can be stowed away while you go off-road or lap your favorite circuit.

From those grassroot beginnings to this day, we maintain our passion and drive, continuing to explore and develop the original concept – always designing and manufacturing to the highest standard. We believe gear that performs at the highest level allows riders to embrace their adventure and enjoy the day – whether out on the trails pushing your own boundaries, or having a blast with your mates.

Ultimately it comes down to peace of mind...on and off the road for motorcyclists ready for adventure and play.

Our latest design is a testament to our dedication and the pursuit of excellence. CLICKnRIDE products incorporate the highest quality parts and materials we can find, with a design that is practical, universally stylish, has built-in strength and durability and is easy to fit.

We understand riding is a great pastime, a great sport – but it's also a way of life and we owe it to ourselves to make as much time as possible to do the things we truly live for.

**CLICK'N'RIDE®**  
QUICK RELEASE MOTORCYCLE TURN SIGNALS

DIRT ADVENTURE TRACK



# Prima



First released in 2017, CLICKnRIDE removable turn signals quickly became the rider's choice in Australia... and are still going strong.



## Prima Series Removable LED Turn Signals

CLICKnRIDE removable turn signals revolutionised rider safety and convenience - emerging from trails with busted blinkers became a thing of the past. Our ongoing commitment to great design and function has meant we've packed in a whole lot of goodies into our turn signals, whilst enhancing the bike's appearance: a combination of sculpted, highly polished and frosted surfaces with 3D 'catseye' lenses; high output Philips SMD LEDs for a super bright, amber light; built-in mud and dirt guard and of course our legendary quick-release tech. The simple, universal mounting and quick-release system lets riders remove their turn signals in an instance - ready to take on the day.



E24

50R-20 0313 Patent design

CODE	DESCRIPTION	BODY COLOR
4202	PRIMA LED TURN SIGNAL - 2 SET PACK	BLACK
4204	PRIMA LED TURN SIGNAL - 4 SET PACK	BLACK

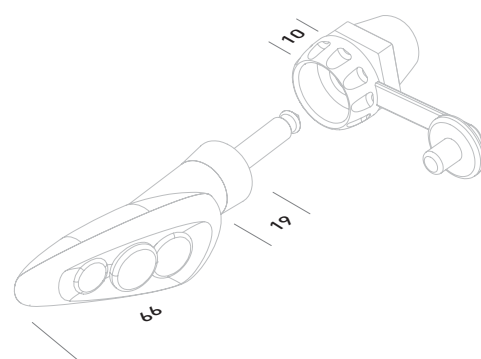





Oh yeah, they're bright. The photo opposite was taken with no filters and no photoshop enhancements at our home base and testing grounds in the Snowy Mountains, NSW, Australia.

## **Our Dealers are the life blood of our business.**

The biggest challenge we faced in the early days was getting the word out. Once riders started to hear about CLICKnRIDE removable turn signals everything changed up a few notches. Suddenly, Dealers were very keen to get in touch as rider after rider started asking their local shop owners if they had any stock.

That's the point where we turned off our e-commerce shop and went 100% direct-to-dealer wholesale... and we've never looked back.







# Nova



ADventure starts here with an all new series of CLICKnRIDE removable LED turn signals. Two years of research, design and development,

## Nova Series Quick-Release LED Turn Signals

Nova Series features our patented quick release technology that provides a secure and reliable connection with haptic feedback as the light is ejected into the rider's hand, and an audible click as it locks in. Simply release the turn signal and stow it safely away to avoid any damage from swiping trees and branches or dropping your bike.

With a beautifully designed high quality metal casing, super bright custom COB LED strip, innovative 3D lens array, silicon seals and caps to keep the water and dirt out and a standard M8 thread, the new Nova Series can be easily installed on any dirt, adventure, road or track motorcycle - ready to go where riders dare!

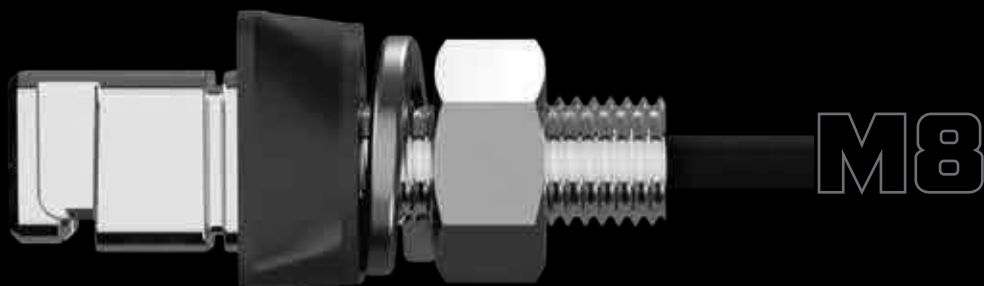

high quality materials and fine tuning has delivered the world's best turn signal... that stores away safely when you go off-road or lap tracks.

# Quick Release Haptic Technology

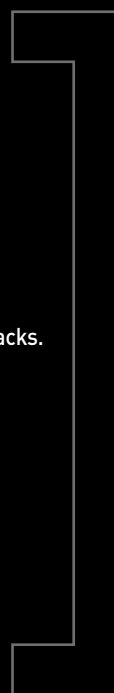
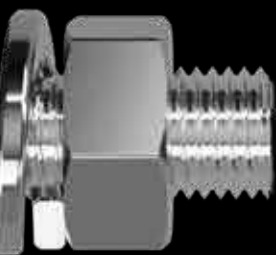

Pending approval Registered Patent pending technology

CODE	DESCRIPTION	BODY COLOR
4220	NOVA LED TURN SIGNAL - METAL BODY	CARBON BLACK
4221	NOVA LED TURN SIGNAL - METAL BODY	GUNMETAL

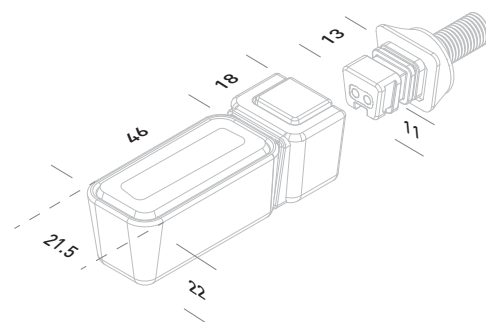







# Accessories

Quick-Release Motorcycle Turn Signal

Unique to CLICKnRIDE, extra sockets can be purchased individually, allowing you to share lights between all your bikes. Each accessory has been created to compliment the system.

CODE	DESCRIPTION	VISUAL REFERENCE
4205-L 4205-R	SPARE LIGHT - RIGHT REAR / LEFT FRONT SPARE LIGHT - LEFT REAR / RIGHT FRONT	
4206	SPARE SOCKET	
4207	RESISTORS (PAIR)	
4211 4212 4213 4214 4215 4216 4217 4218	<b>HARNES CONVERTERS - PLUG &amp; PLAY</b> KTM, HUSQVARNA, GAS GAS, DUCATI YAMAHA FRONT/REAR CONNECTOR HONDA FRONT 3-PIN CONNECTOR (WITH AUX) HONDA REAR 2-PIN CONNECTOR SUZUKI FRONT 3-PIN CONNECTOR, YAMAHA SUZUKI REAR 2-PIN CONNECTOR UNIVERSAL 45CM EXTENTION LEADS YAMAHA TYPE 2 (e.g. Tenere)	

Contact 360 TWO Pty Ltd for Pricing.

# Ordering

Quick-Release Motorcycle Turn Signal

Contact 360 TWO Pty Ltd to receive our Price List.  
We've made ordering as simple as possible.



Simply log onto the Australian website Reseller Page and fill out the Online Order Form:  
<https://clicknride.com.au/index.php/reseller-orders/>

Use Password (case sensitive):  
**clicknridereseller**



**EMAIL**  
**sales@clicknride.com.au**

Generally, we ship goods same day (for orders received before 11:00am - Sydney time) via international parcel post on the Australia Post network. Courier services, insurance and registered delivery is available upon request.

Terms and Conditions are available on the CLICKnRIDE website:  
<https://clicknride.com.au/index.php/reseller-terms-and-conditions/>

#### CERTIFICATION & HOMOLOGATION

CLICKnRIDE® Prima Series has been independently tested by an accredited Test Lab to meet the UNECE Regulation 50 Standard (E-Mark), making CLICKnRIDE® Prima Series removable turn signals fully certified in countries that subscribe to the UNECE standard. Please refer to our website's FAQ section for a list of countries. In other countries, our products are not legally certified for public roadway use and should be used in off-road or closed-course conditions. At the time of publication, Nova Series is still in production and the product will undertake the same testing and approvals prior to being commercialized.

All details in this catalog are correct at the time of publication. 360 TWO Pty Ltd reserves the right to modify and/or improve the products without prior notice.

#### LEGAL NOTES

360 TWO Pty Ltd cannot be deemed liable for the damages whatsoever resulting from installation or a use of its products that does not comply with the safety regulations of the Countries in which the products are sold.

The trademarks KTM®, HUSQVARNA®, HONDA®, SUZUKI®, YAMAHA® belongs to its proprietor.

360 TWO Pty Ltd, CLICKnRIDE® and KTM®, HUSQVARNA®, HONDA®, SUZUKI®, YAMAHA® are distinguished entities between which there is not any kind of connection.

The design and innovation in our products is unique to 360 TWO Pty Ltd and CLICKnRIDE® and is protected by patents and trademarks issued or registered in the United States Patent & Trademark Office, and authorities in other countries.



*DIRT ADVENTURE TRACK*

360 Two Pty Ltd  
PO Box 1106  
Jindabyne NSW 2627  
Australia

**Sales & Enquiries: +612 6430 8616**  
**Email: [sales@clicknride.com.au](mailto:sales@clicknride.com.au)**  
**Web: [clicknrideusa.com](http://clicknrideusa.com) / [clicknride.com.au](http://clicknride.com.au)**

#### **Statement of Confidentiality**

This proposal and supporting materials contain confidential and proprietary business information that is privileged, confidential or otherwise protected from disclosure. The material is not to be shared, copied with others in any way without our prior written authorisation.